

INSTALLATION INSTRUCTIONS



For more information contact...

WOODFORD MANUFACTURING COMPANY

2121 Waynoka Road, Colorado Springs, Colorado 80915 • Phone: (800) 621-6032 • Fax: (800) 765-4115

To view our complete product line visit: www.woodfordmfg.com or email: sales@woodfordmfg.com

A Division of WCM Industries, Inc.

Rev 06/10 Form No. II22.102

Model 22 & V22

HOT & COLD

Freezeless Wall Faucet



Model 22
Anti-siphon protected



Model V22
Anti-siphon protected

FIGURE 1-22

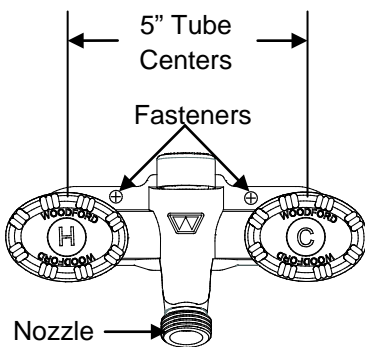

FIGURE 2-22

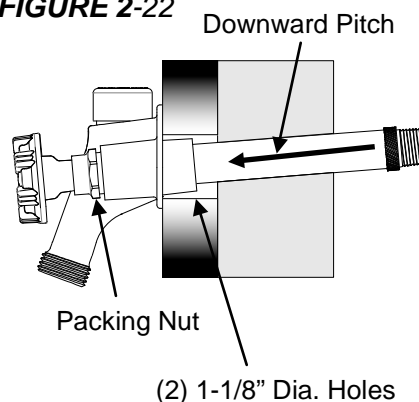

FIGURE 1-V22

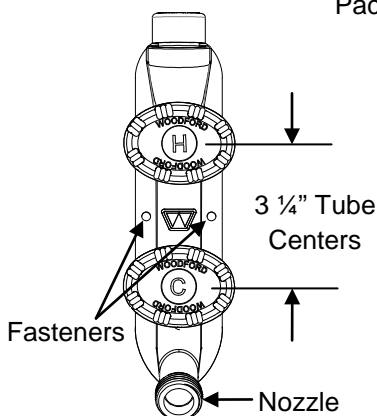
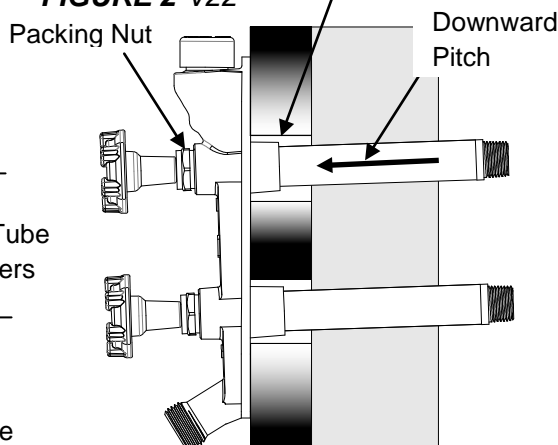

FIGURE 2-V22



Wall faucets must be properly installed and operated to insure drainage. Improperly installed or operated wall faucets may freeze and burst in freezing weather.

INSTALLATION INSTRUCTIONS:

1. Before installation, flush supply line to remove any debris.
2. Drill (2) 1-1/8" diameter holes through the wall in the desired location and insert the faucet from the outside. **FIGURE 1**
 - a. Drill (2) holes for the horizontal mounted Model 22 water tubes on 5" centers.
 - b. Drill (2) holes for the vertical mounted Model V22 water tubes on 3 1/4" centers.
3. Install faucet with nozzle pointing down. **FIGURE 1**
4. The water tubes must have a slight downward pitch for proper drainage. *Proper drain angle is built in to the faucet head if mounted on a vertical surface.* **FIGURE 2**
5. Secure faucet to the wall using appropriate fasteners installed through the holes in the flange. **FIGURE 1**
6. *For a solder connection inlet*, open faucet to full open position before soldering. Excessive heat can damage valve seat rubber or stainless steel seat and factory solder joint.

NOTE: The packing nut, located behind the handle, has been factory adjusted. If leakage should occur after installation or use, the packing nut can be tightened to stop the leak. **FIGURE 2**