



Freezeless Sanitary Heated Yard Hydrants Model H34

The Model H34 is a sanitary, frost proof yard hydrant. When the hydrant is shut off, all water is contained in the hydrant and piping system, instead of draining into the sub-soil. The thermostatically controlled heating element keeps the water in the hydrant from freezing even at temperatures down to 20 degrees below zero. An ASSE 1052 approved Model 50HF Backflow Preventer protects the hose connection from backflow contamination in freezing and non-freezing conditions.

The H34 is easy to install, since its connection to the piping system only extends one foot below finished grade. All preventative maintenance procedures and repairs can be completed from the top of unit, without removing hydrant from the source piping.

SPECIFICATIONS:

Hydrant is 1057 Approved

MODEL 50HF BACKFLOW PREVENTER -

Patent Information:

<http://www.woodfordmfg.com/Woodford/patents/>

- ASSE 1052 Approved
- Listed by IAPMO
- Field Testable
- Two Independent Check Valves
- Drains automatically when hose is removed
- No spray back

FEATURES:

Heater Element: Thermostatically controlled 65 watt, 120 volt, 60 cycle, low watt density heating element.

Electrical Cord: H34 includes 3' cord

H34-C12 includes 12' cord

H34-C25 includes 25' cord

Construction: Brass head and heater cap

Casing: 1" Galvanized steel pipe

Male Inlet: 1" NPT

Outlet Nozzle: 3/4" male hose thread

Conduit Fitting: 1/2" NPT female

Handle: Polycarbonate wheel handle
Optional: Metal Handle

Max Pressure - 125 p.s.i.

Max Temperature - 120° F

Shipping Weight: 13 lbs each

Patent Pending

**For Installation / Troubleshooting Instructions go to
www.woodfordmfg.com or call 1-800-621-6032**

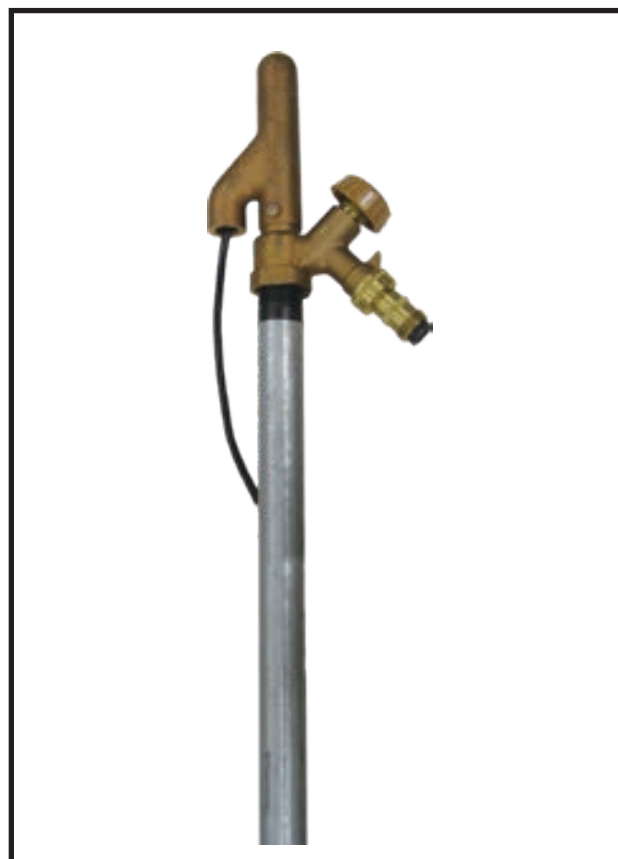

Rough In

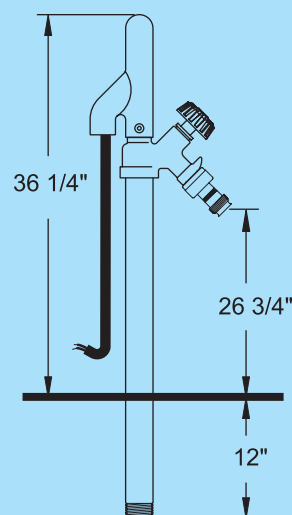

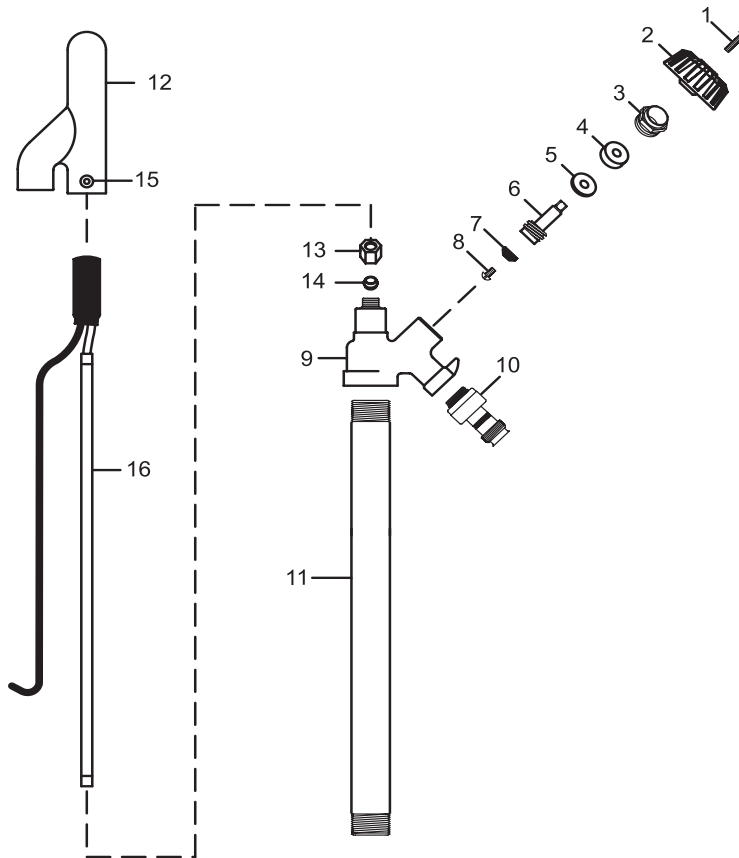

MODEL H34 PARTS LIST

ITEM	PART#	DESCRIPTION
1	30002	Handle Screw
2	30233	Wheel Handle
3	30107	Packing Nut
4	30247	EPDM Packing
5	30105	Packing Washer
6	30104	Operating Stem
7	30008	Washer
8	30009	Washer Screw
9	10542	H34 Head
10	50HF-BR	50HF Backflow Preventer - Brass
11	10610	1" Pipe Casing
12	10541	H34 Heater Cover
13	10544	Compression Nut
14	10545	Compression Sleeve
15	10546	Set Screw (2)
16	10543	H34 Heater Assembly - includes 3' Cord
16a	10599	H34 Heater Assembly - includes 12' Cord
16b	10560	H34 Heater Assembly - includes 25' Cord
	RK-H34	Repair Kit (Includes Items 1-8)
	RK-HTR	Repair Kit (Includes Items 13-16)

Installation example to meet local and state electrical codes

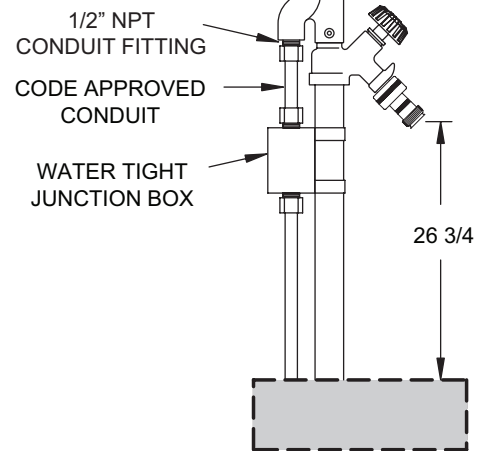

For more information contact...

WOODFORD MANUFACTURING COMPANY, LLC.

2121 Waynoka Road, Colorado Springs, Colorado 80915 • Phone: (800) 621-6032 • Fax: (800) 765-4115
 To view our complete product line visit: www.woodfordmfg.com or email: sales@woodfordmfg.com